



CMA-44L

Chemical Sanitizing
44" Conveyor
Dishwasher

NEW 2008 CMA-44 CONVEYOR



FEATURES:

- NEW** Auto re-fill system.
 - 242 racks / 968 covers per hour.
 - Economical to operate. Uses only .8 gallons of water per cycle.
- NEW** Single control switch activation.
 - Unique 3-stage washing process provides pre-wash, power wash and final rinse all in a 44" machine.
- NEW** Brass rockerarm bearing (extends longevity) newly engineered.
 - Automatic soil purging system filters wash water and traps plate debris into an external tray. Tray can be easily removed for dumping contents.
 - All stainless steel construction offers durable performance and years of trouble free operation.
- NEW** Upgraded high load power contactors.
 - Chemical resistant industrial 10kW heater is proven to be more durable than commercial grade heaters.
 - Large 19" high opening accommodates larger items and utensils.
 - Auto start/stop makes operation safe and easy.
- NEW** Easy to remove and replace curtains.
 - Includes table limit switch and rack saver clutch system that protects the machine, dishracks and table from damage.
- NEW** Chemical resistant mixing chamber.
 - Auto Fill.
 - Built-in Poly Pro™ scarp accumulator.



Rack saver clutch system with new brass rockerarm bearing protects the machine, dishracks and table from damage.



Strategically located spray arms with spray pattern positioned for additional wash coverage.



Large 19" opening accommodates larger items and utensils.

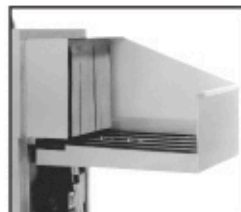

Shown with optional corner feed table. Available right or left.

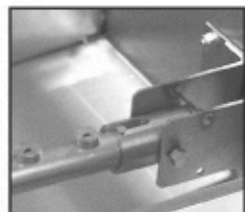

Easy to remove wash arms with captive end caps. **Never lose another end cap again!**



Single action control switch with easy to read temperature gauges and complete operating instructions.

WARNING: Plumbing connections must be made by a qualified service company who will comply with all available Federal, State, and Local Health, Plumbing and Safety codes.

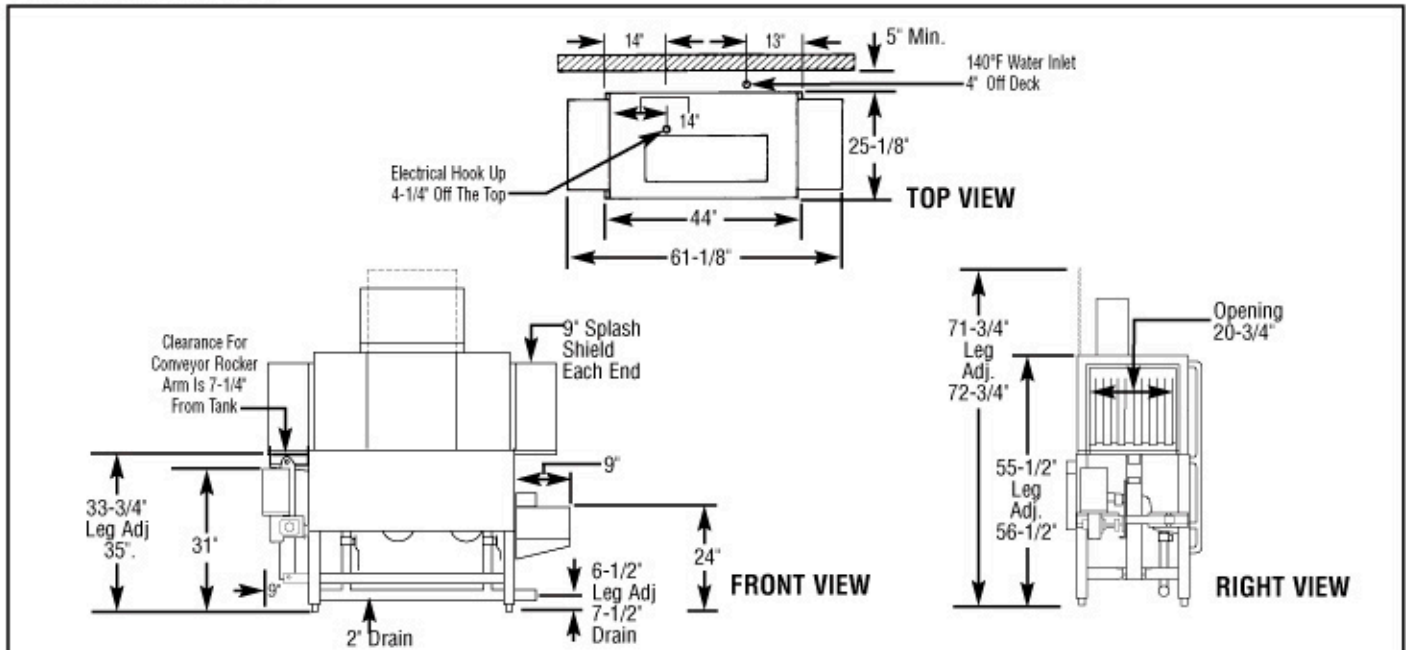
Specifications:

	USA	METRIC		USA	METRIC	
OPERATING CAPACITY			DIMENSIONS			
RACKS PER HOUR (NSF RATED)	242	242	DEPTH	25-1/8"	(64cm)	
CONVEYOR SPEED	6.75 FT./MIN.	(206 CM/MIN.)	WIDTH	44"	(111.7cm)	
DRAIN	2"	-	HEIGHT	55-1/2"-56-1/2"	(140.97-143.51cm)	
WASH PUMP MOTORS HP (2)	1	1	STANDARD TABLE HEIGHT	34"	(86cm)	
CONVEYOR MOTOR HP	1/3	1/3	MAX HEIGHT CLEARANCE FOR DISHES	19"	(48cm)	
WATER INLET - FILL	3/4"	-	STANDARD DISHRACK	1	1	
WATER INLET - FINAL RINSE	1/2"	-	DIMENSIONS	19-3/4"X19-3/4"	(50X50cm)	
WASH TANK CAPACITY			ELECTRICAL RATING	VOLTS	PHASE	AMPS
PRE-WASH	4.25 GAL	(16.0 L)		208	1	64
WASH	11.75 GAL	(44.5 L)		240	1	71
TOTAL	16.0 GAL	(60.5 L)		208	3	36
WASH PUMP CAPACITY				240	3	40
EACH	52 GPM	(197 LPM)	BOOSTER HEATER	10kW		
OPERATING TEMPERATURE			SPECIFY DIRECTION OF RACK TRAVEL (RIGHT TO LEFT, LEFT TO RIGHT) WHEN ORDERING			
WASH	140°F-150°F	(60°C/65.5°C)	SHIPPING WEIGHT			
FINAL RINSE	140°F-150°F	(60°C/65.5°C)	APPROXIMATE	662#	(300kg)	
WATER CONSUMPTION						
PER RACK (FINAL RINSE)	.8 GAL	(3 L)				
PER HOUR (FINAL RINSE)	192 GPH	(726.6 LPH)				

Summary Specifications: Model CMA-44L

The Model CMA-44L low energy, chemical sanitizing conveyor dishwasher meets NSF, UL, and CUL sanitation and construction standards WITHOUT the use of a BOOSTER HEATER. The CMA-44L performs three separate washing functions including a built-in pre-wash, all in a 44" space. The CMA-44L washes up to 242 racks per hour and uses a minimum .8 gallons of water per rack while achieving sparkling, clean, dry dishes. Constructed entirely of stainless steel.

Available Models

- CMA-44L R/L Right to Left
- CMA-44L L/R Left to Right

Available Options

- Corner Feed Table (**FACTORY INSTALLED ONLY**)
- Alternative electrical options
- Also available at 205 or 167 racks/hr
- Stainless steel dishtables
- Vent Hood with 4" X 16" Vent and Damper Control (2 per set)
- Motor Cover